

# DEVELON

Excavator

## DX27Z-7K DX35Z-7K

Zero-tail swing excavator



# WE ARE BACK WITH NEW FEATURES

---

## PERFORMANCE

- Strong lifting and digging force
- Excellent travel performance
- Outstanding controllability reflecting customer needs
- Standard application of rotating piping
- Automatic traveling shift function applied when driving
- Blower-type engine cooling for higher efficiency

---

## NEW FEATURES

- New design
- Optional cabin / canopy specifications
- Zero - tail swing radius
- The boom swing function allows you to work in very narrow areas
- Boom / Arm / Bucket cylinder guard
- Canopy with tip-over protective structure (TOPS)
- Cabin with roll-over protective structure (ROPS)
- Dozer floating function added
- Additional Tie-down holes for transport





---

### CONVENIENCE AND MAINTENANCE

- Removable canopy ( Canopy type )
- Front footrest in the cab ( Canopy type )
- 12V power socket
- Large storage space
- Wrist rest
- Heater and air conditioner (Optional)
- Thumb wheel joystick (Optional)
- Easier hydraulic oil refilling
- Better battery access
- Fuel level indicator lamp

---

### DELUXE INTERIOR FOR CABIN

- Powerful air conditioner ( Optional )
- Heating and cooling seat ( Optional )
- Rear view camera ( Optional )
- USB charging
- 5.7-inch LCD gauge panel ( Optional )
- Bluetooth audio ( Optional )
- DEVELON Fleet Management
- Cabin with roll-over protective structure ( ROPS )
- Full glass door
- Improved front visibility

# HIGH PRODUCTIVITY AND LOW COST OF OWNERSHIP

- Excellent job performance based on powerful lifting and digging force.
- Delivers higher productivity and reduced fuel consumption for efficient and comfortable work environment .



· The photos in this brochure contain optional specifications, so they may differ from the actual product.

# Canopy type

## POWERFUL HVAC SYSTEM

The operator can keep warm in a cold working environment.



**EXCLUSIVELY, FOR OPERATOR.**

## INTEGRATED GAUGE PANEL

The integrated gauge panel allows the operator to check equipment information easily.



## EQUIPPED WITH A POWERFUL ENGINE

The eco-friendly engine meets the Tier4 final and Stage V emission regulation without DPF and requires no urea solution.



## ROTATING PIPING

The installed attachments expand the equipments usability.



## BOOM / ARM / BUCKET CYLINDER GUARD

The boom, arm and bucket cylinder guard protects the cylinder from external impact.



## AUTO - SHIFT

The auto-shift automatically shifts travel speed from high to low, depending on traction and terrain, allowing smoother operation when dozing and turning.



## JOYSTICK THUMB WHEEL SWITCH

1 way, 2 way and rotating operation with the joystick thumbwheel button.



## ZERO TAIL WITH ADDITIONAL COUNTERWEIGHT

The excavator is equipped with a zero tail design for enhanced maneuverability in confined spaces.



## DETACHABLE CANOPY

Canopy can be removed conveniently without alteration (TOPS-certified canopy)



## BOOM LED LAMP

The LED lamp with excellent illumination increases visibility.



## FOOTREST

A footrest on the front of the cab is a standard feature.



**BOOM SWING ANGLE**

**THE BOOM SWING FUNCTION ALLOWS YOU TO WORK IN VERY NARROW AREAS .**



#### **NEW CABIN FEATURES**

The new cabin features ensure comfortable operation regardless of weather.

# Cabin type

## ROPS (ROLL-OVER PROTECTIVE STRUCTURE) CABIN

The ROPS provides protection in the event of accidental rollovers and falling objects.



**ERGONOMICALLY DESIGNED WITH COMFORT IN MIND.**

## MECHANICAL SUSPENSION SEAT WITH HEATING

Built-in hot wires keep the operator warm and comfortable when working in cold working environments.



## FULL GLASS DOOR CABIN

An unobstructed front view enables the operator to work comfortably.



## REAR VIEW CAMERA

An unobstructed rear view enables the operator to work safely.



## FRONT GLASS TO SLIDE OPEN

Improved work convenience



## NEW DIGITAL GAUGE PANEL

The operator can check information and set functions of the equipment with the 5.7-inch color monitor.



## POWERFUL HVAC SYSTEM

The high-performance air conditioner keeps the operator cool and comfortable even in the hot summer.



## FRONT AND REAR WORK LIGHTS

The lights keep the work environment bright enough to ensure safe and comfortable work.



## AUDIO

The Bluetooth function support allows the operator to make phone calls and listen to music.



## EMERGENCY STOP SWITCH

The switch is located at the bottom of the seat to stop the engine in an emergency.



## POWER SOCKET AND USB CHARGER

They can be used for charging smartphones and other devices.

## DEVELON Fleet Management

The operator can check equipment information with a smartphone or a computer in real time.



## Dimension

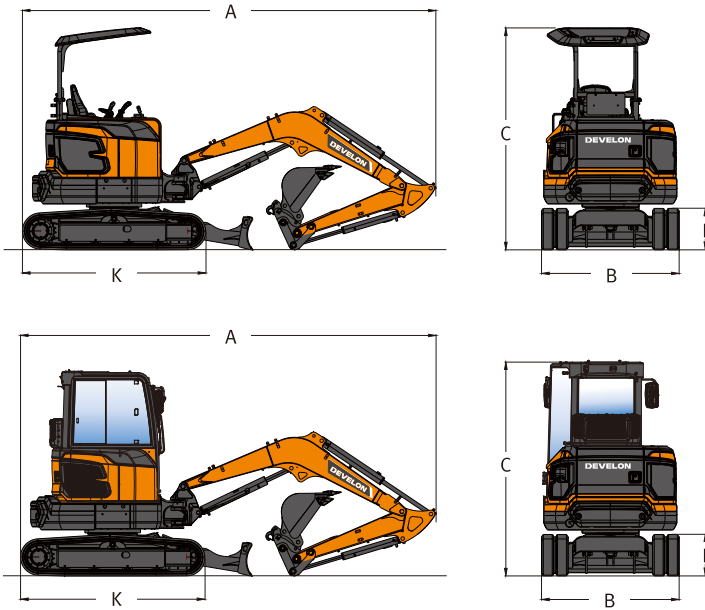

## Working Range

Unit : mm

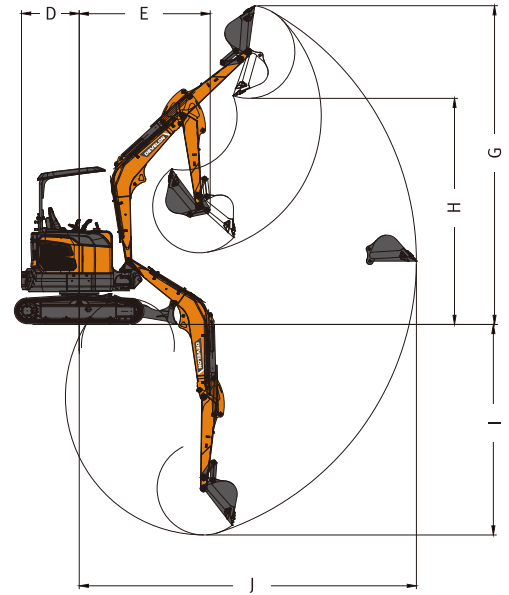

## Specifications

Description		Unit	DX27Z-7M		DX35Z-7M	
			Canopy	Cabin	Canopy	Cabin
Operating weight		kg	2,688	2,816	3,817	3,938
Bucket capacity		m <sup>3</sup>	0.06		0.11	
Engine	Model	-	KUBOTA V1505		DEVELON DW01	
	Rated power	kW / rpm	18.5 / 2,300		18.4 / 2,200	
	Max. torque	kg.m / rpm	9.4 / 1,700		10.4/1,600	
Hydraulic	System pressure	bar	216		245	
	Max. flow	ℓ / min	2 X 28.8 + 19.2		2 X 37.0 + 20.7	
Performance	Travel speed (High / Low)	km/h	4.2 / 2.4		2.5 / 4.3	
	Swing speed	rpm	9.1		8.3	
	Digging force (Bucket / Arm)	ton	2.22 / 1.45		3.24 / 2.12	
	Gradeability	degree (°)	30		30	
Dimension	Overall length (A)	mm	4,168		4765	
	Undercarriage width (B)	mm	1,550		1700	
	Overall height (C)	mm	2,442		2,510	
	Tail swing radius (D)	mm	790		875	
	Min. swing radius (E)	mm	2,096		2,115	
	Track height (F)	mm	451		488	
	Track length (K)	mm	1,960		2,128	
	Boom length	mm	2,090		2,535	
	Arm length	mm	1,100		1,330	
Working range	Max. digging height (G)	mm	4,385		5,095	
	Max. loading height (H)	mm	2,935		3,580	
	Max. digging depth (I)	mm	2,645		3,275	
	Max. digging reach (J)	mm	4,520		5,355	
	Boom swing angle (left / right)	degree (°)	60 / 60		60 / 60	
Dozer blade (width x height)		mm	1,550 x 289		1,550 X 380	
Shoe width		mm	300		300	
Ground pressure		kgf/cm <sup>2</sup>	0.29	0.28	0.35	0.34



<https://global.develon-ce.com>

©HD Construction Equipment. All rights reserved.  
2026.02

Certain specifications may differ from actual results based on engineering calculations. Specifications are for comparison purposes only and are subject to change without notice.

The specifications of individual DEVELON equipment may vary due to normal changes in design, manufacturing, operational conditions, and other factors. Some images of DEVELON equipment may show non-standard configurations.